

MODEL: CLIVUS MULTRUM™ 10 (CM10)

Overall Dimension: 1550 x 1560 x 1100 mm (L x W x H)
 Projected Capacity: 25 visits daily (average) or 10,000 visits annually
 Description:

The CM10 is a wider version of the CM8, but designed to accommodate two pedestals.

Specifications:

Material	Low Density Polyethylene – LDPE
Waste Chamber	Stainless Steel Baffle Air Duct Polyethylene Rear Baffle Inspection/Access Doors
Finished Compost Chamber	1400 x 350 mm Access Lid
Liquid End Product Drain	All Required Fittings Absorption Trenching
Fasteners	Stainless Steel
Fittings	Corrosion Resistant Materials

Minimum preferred distance between to of chamber and floor joists is 150mm

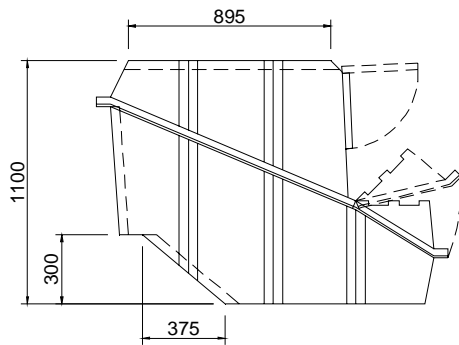

SIDE

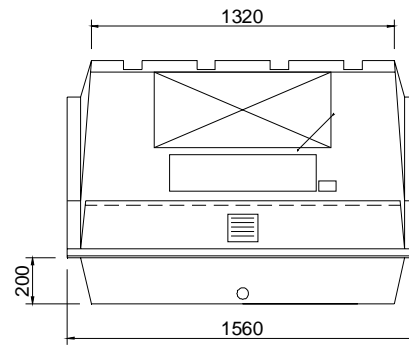

FRONT

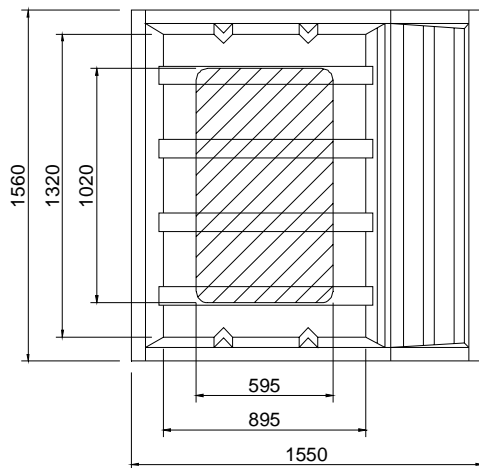

PLAN

TOILET CHUTE/S
 PREFERABLY TO BE
 LOCATED IN HATCHED AREA

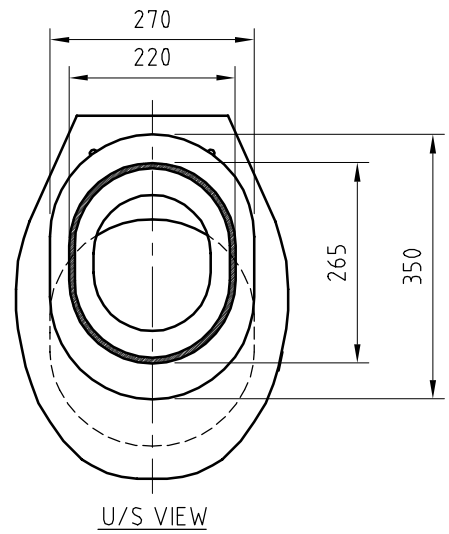
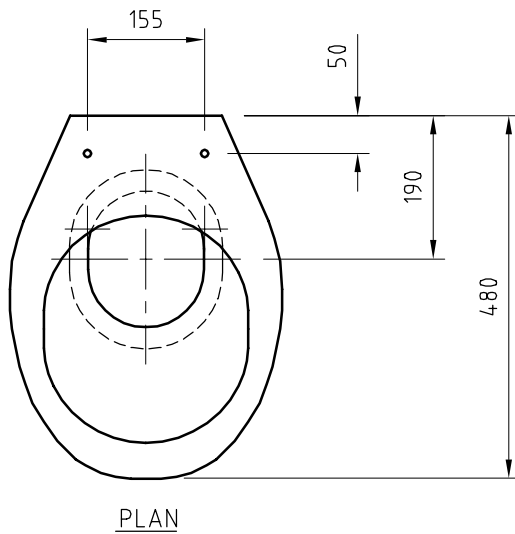
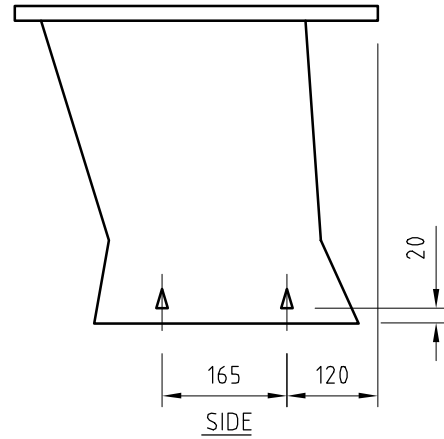
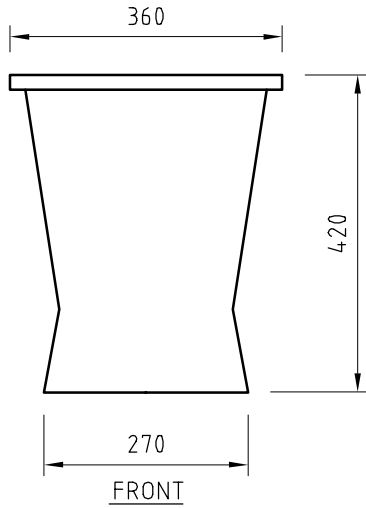

PEDESTAL DETAILS

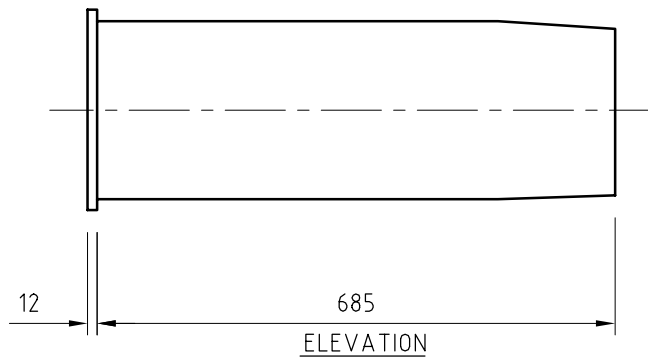
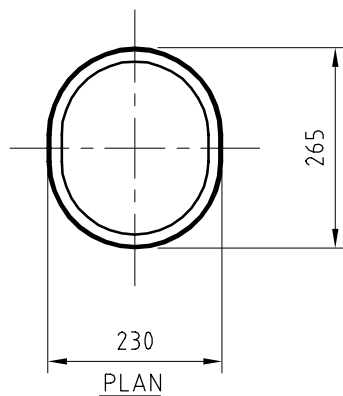

CHUTE DETAILS

NOTES:

1. MANUFACTURING TOLERANCE \pm 2%.

**ISSUED
FOR CONSTRUCTION**

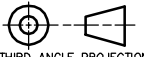
0M1	REVISED DWG	5.12.13	HN
0	IFC	1.2.06	WPM
REV	DESCRIPTION	DATE	BY
 UNLESS OTHERWISE STATED ALL DIMENSIONS IN mm DRAFTING STANDARD AS 1100			

Clivus Multrum Australia
 3/14 Hinkler Court
 BRENDALE QLD 4500
 PH (07) 3889 6144 FX (07) 3889 6149
 www.clivusmultrum.com.au
 ABN 92 360 561 688

NEUBAU PTY LTD

Unit 14, 67 O'Connell Terrace PH (07) 3252 1244 W www.neubau.com.au
 BOWEN HILLS QLD 4006 FX (07) 3004 7401 E admin@neubau.com.au

CLIENT :	CLIVUS MULTRUM AUSTRALIA PTY LTD	A4
JOB TITLE :	CLIVUS MULTRUM TANKS	
DWG TITLE :	PEDESTAL AND CHUTE DETAIL DIMENSIONS	SHEET 1 / 1
SCALE :	1:10	REV OM1
JOB No:	3-020	
DWG No:	CP-A-03	